



Minipack-torre S.p.A.
Via Provinciale, 54 - 24044 Dalmine (BG) - Italy
Tel. (035) 563525 – Fax (035) 564945
E-mail: info@minipack-torre.it
<http://www.minipack-torre.it>



FM90 Digit

Catalogo ricambi
(Valido dalla matricola nr. 98 del 07.2004)
Spare parts catalogue
(Valid from serial number 98 dated 07.2004)



CONSULTARE ATTENTAMENTE QUESTO CATALOGO PRIMA DI ORDINARE PEZZI DI RICAMBIO
CAREFULLY READ THIS CATALOGUE BEFORE ORDERING ANY SPARE PART



DOC. N. FM112081
REV. 0
Ed: 04.2012

УПАКОВОЧНОЕ ОБОРУДОВАНИЕ



ПРОИЗВОДСТВО И ПОСТАВКА
СЕРВИСНЫЙ РЕМОНТ
ЗАПАСНЫЕ ЧАСТИ
РАСХОДНЫЕ МАТЕРИАЛЫ

Диагностика, ремонт, сервисное обслуживание.

Запасные части и расходный материал: резина, тефлоновая лента, термонож (лезвие), гель для смазки.

Плѐнка термоусадочная полиолефиновая.

Система «Trade-In» – замена Вашего оборудования на новое и более производительное.



На фото: запайщик Magnetic FL900 + туннель Magnetic T100

ООО «АРДсистемы»

(495) 231-21-00

(812) 363-20-22

info@ardsystems.ru

www.filmtrade.ru

www.ardsystems.ru

ESPLOSO MACCHINA
MACHINE DETAIL DRAWING

TAVOLA 1
SCHEME 1

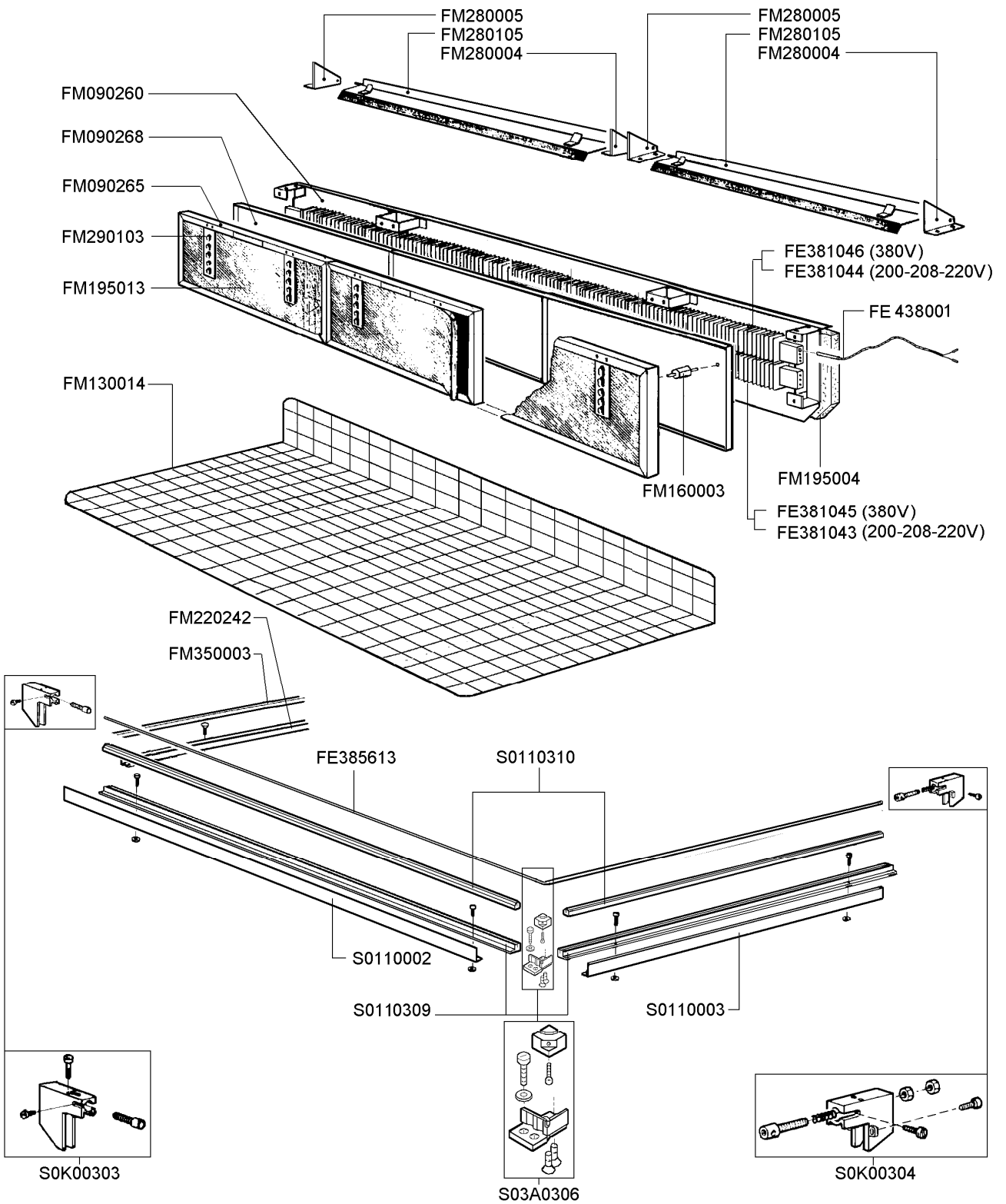

ESPLOSO MACCHINA
MACHINE DETAIL DRAWING

TAVOLA 2
SCHEME 2

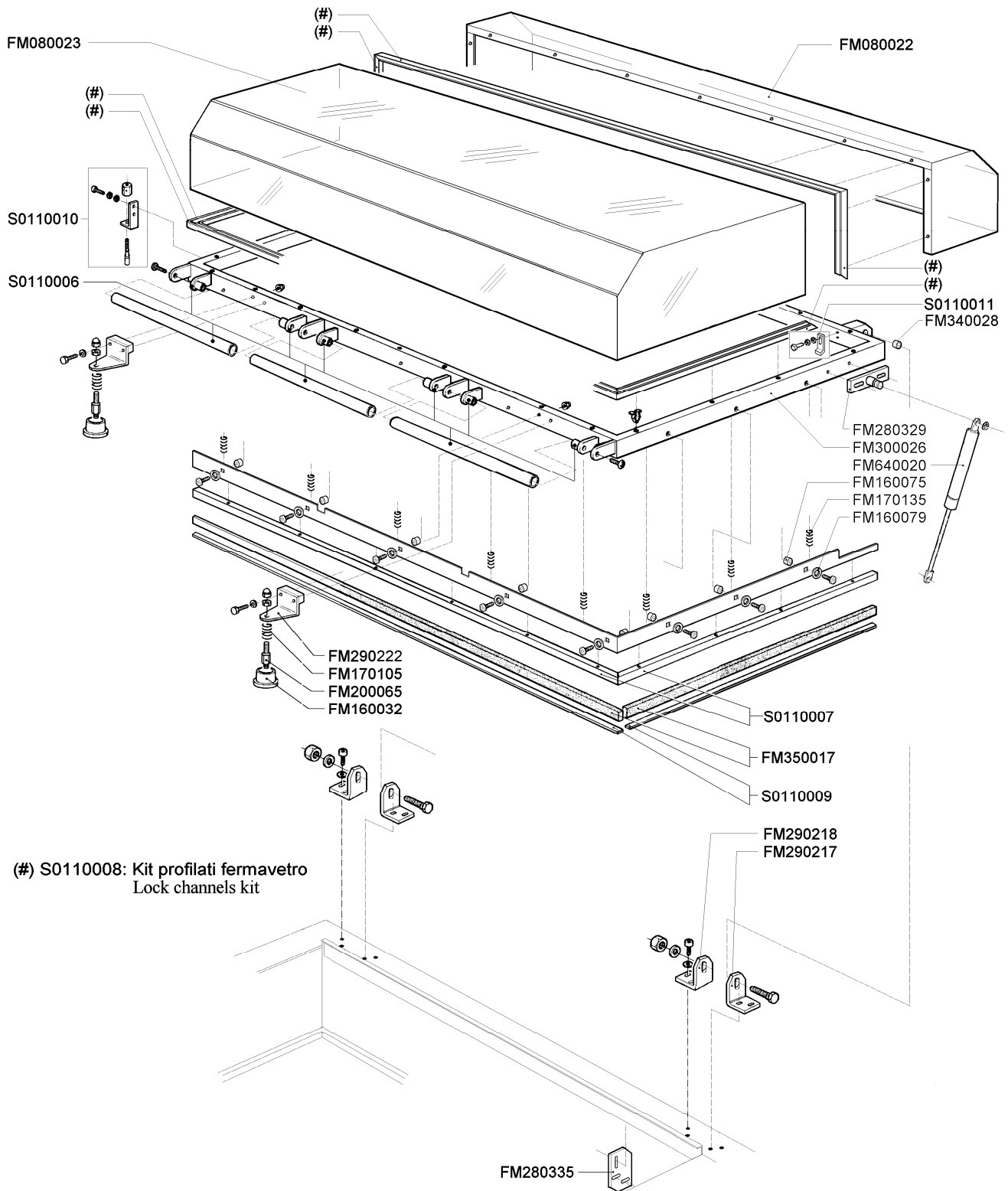

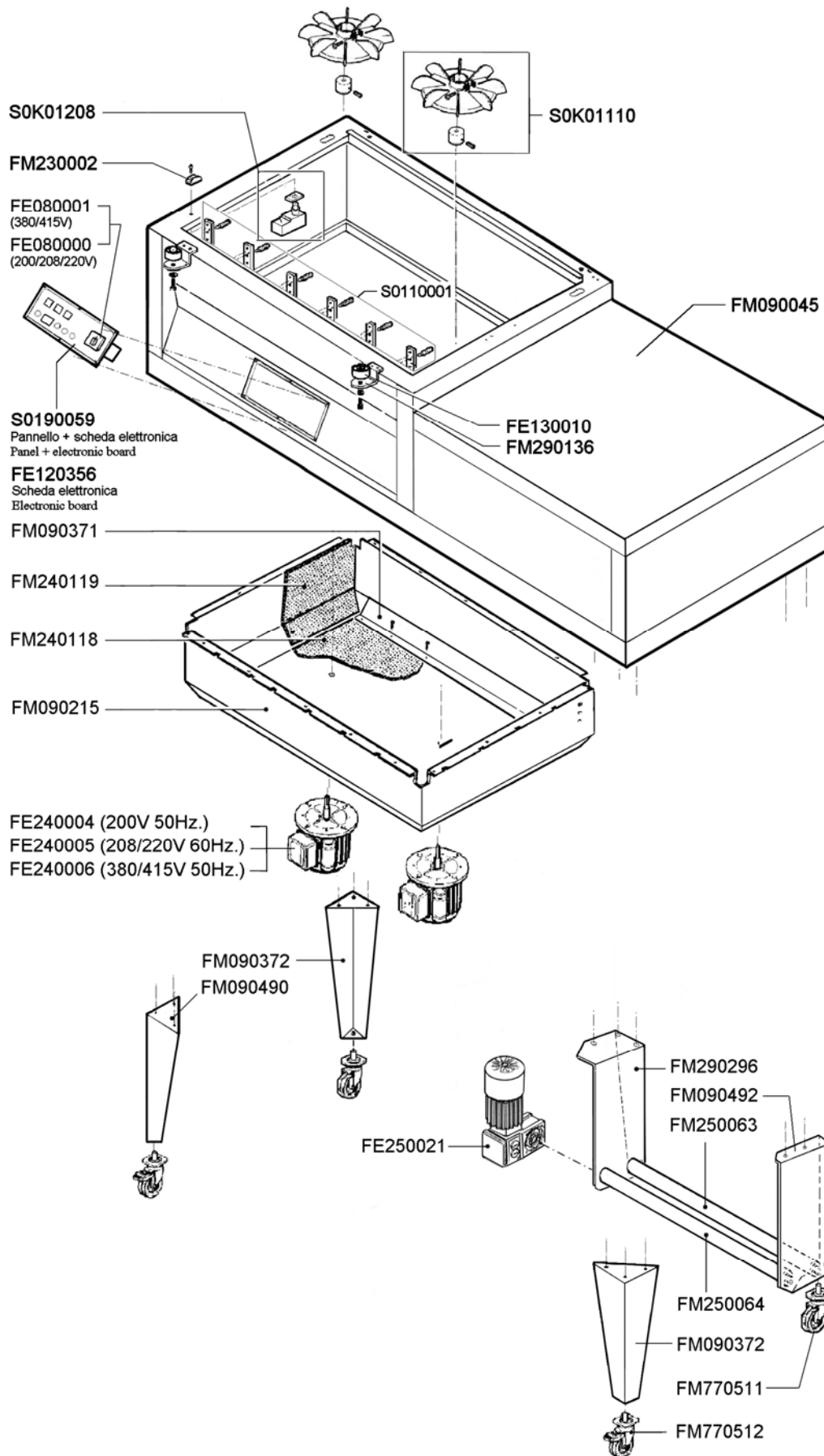

ESPLOSO MACCHINA
MACHINE DETAIL DRAWING

TAVOLA 4
SCHEME 4

Nuovo avvolgitore: valido dalla matricola nr. 111 del 03.2006.
New Rewinder: Valid from serial number 111 dated 03.2006.

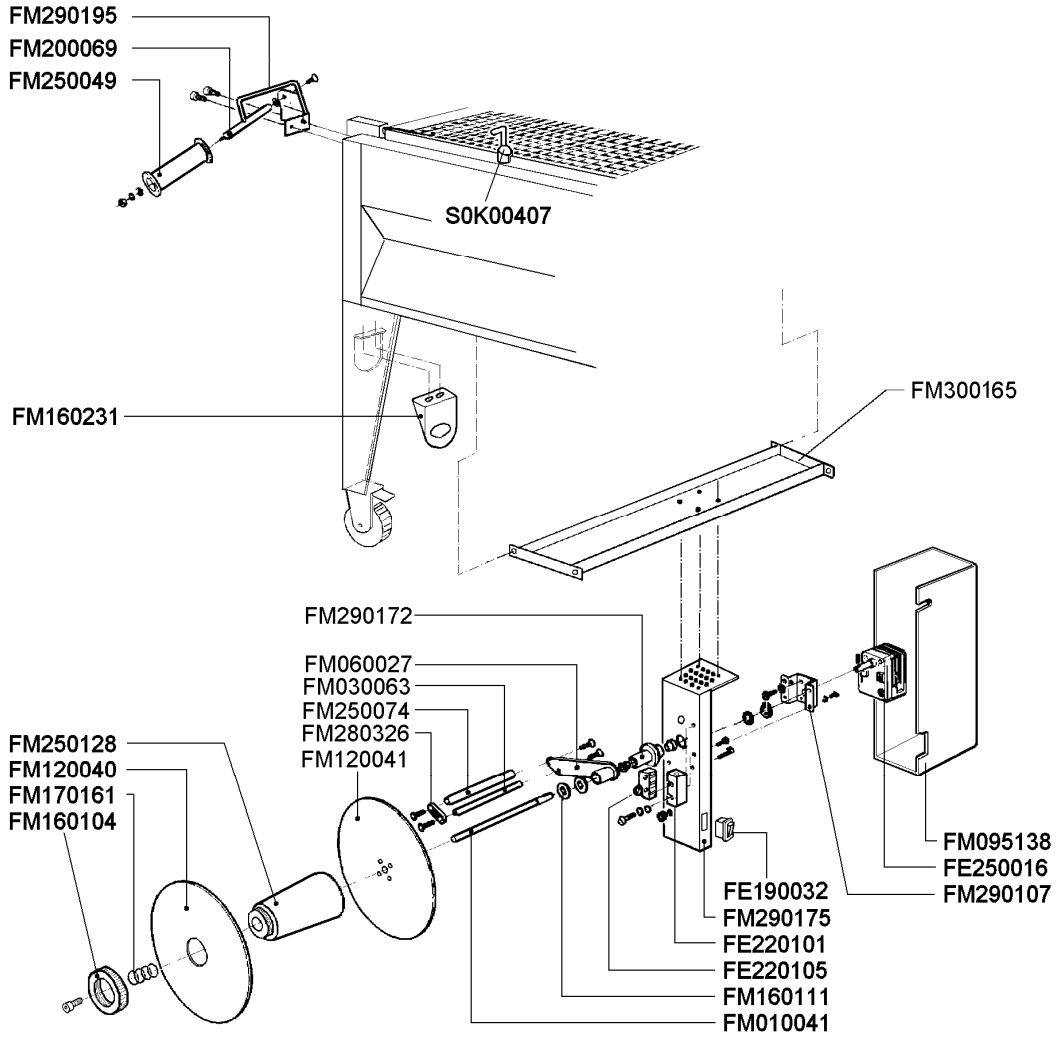

Vecchio avvolgitore: valido fino alla matricola nr. 110 del 02.2006.
Old Rewinder: valid at to serial number 110 dated 02.2006.

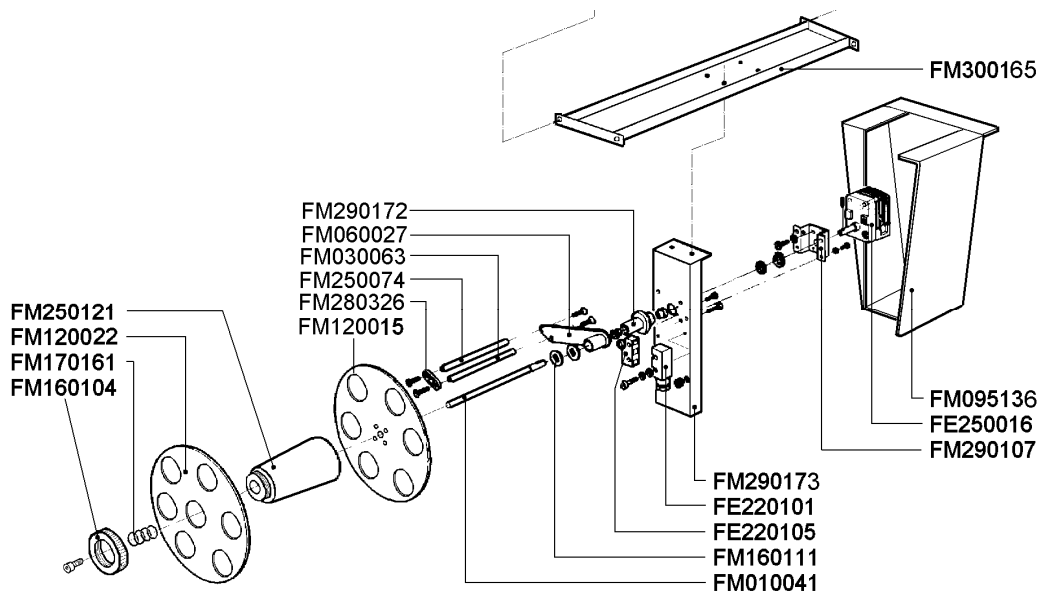

S03A0606

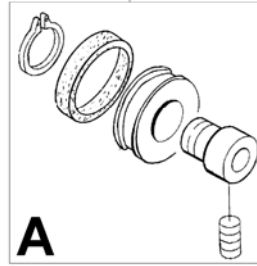

S03A0605

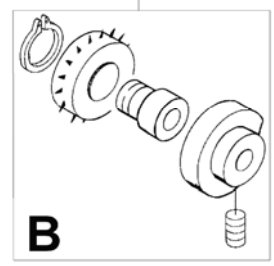

PM110000

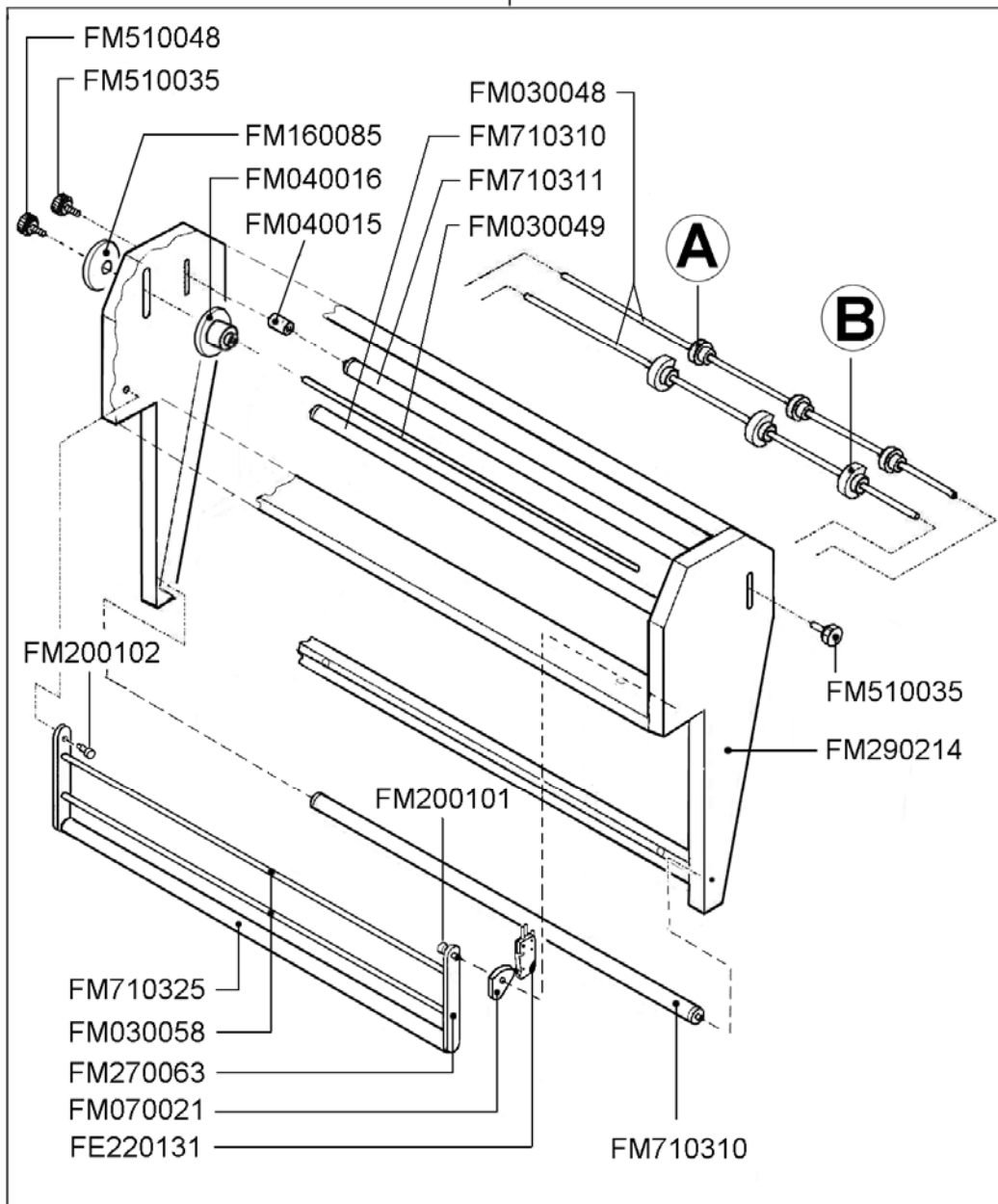

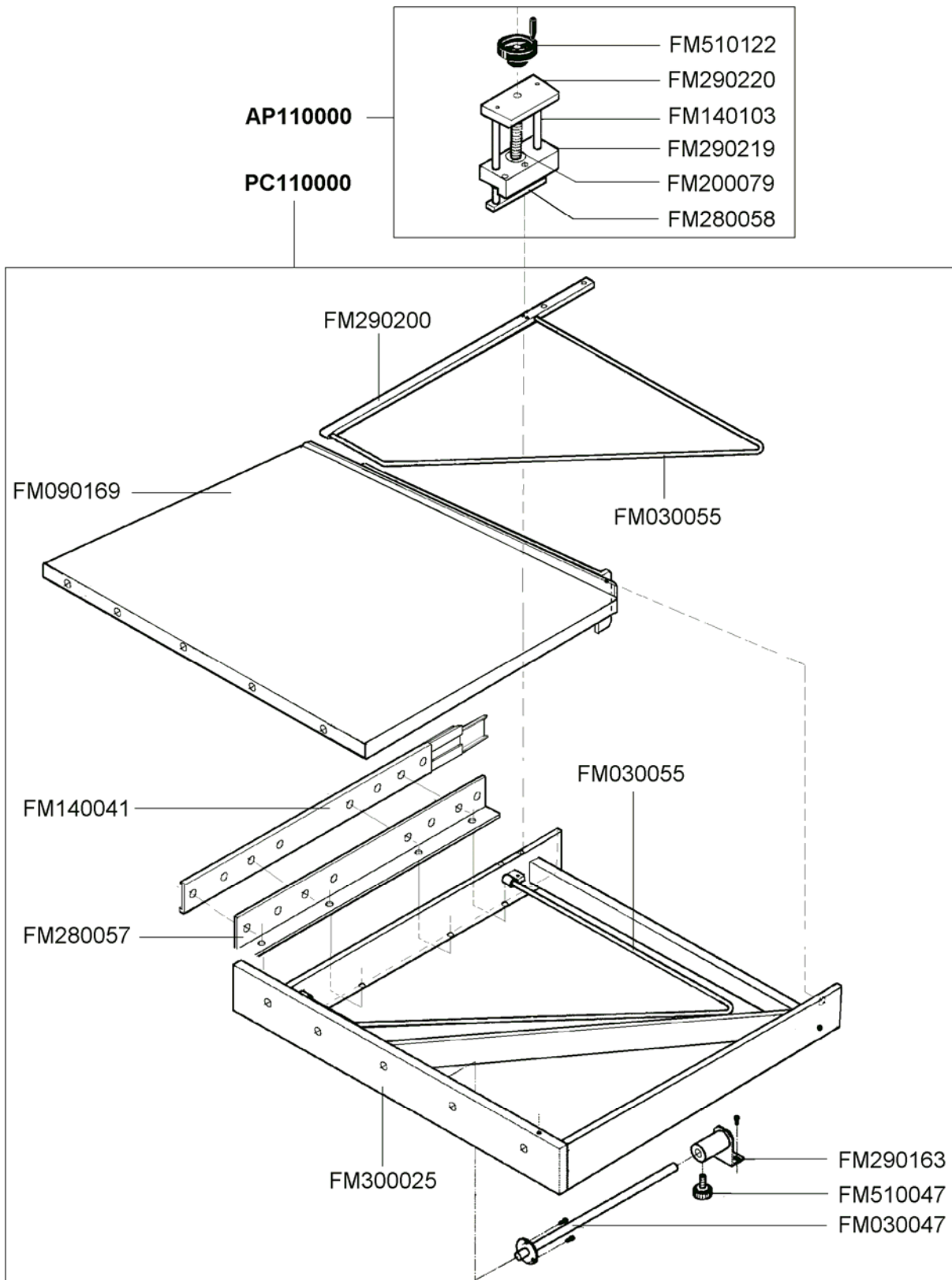

ESPLOSO MACCHINA
MACHINE DETAIL DRAWING

TAVOLA 7
SCHEME 7

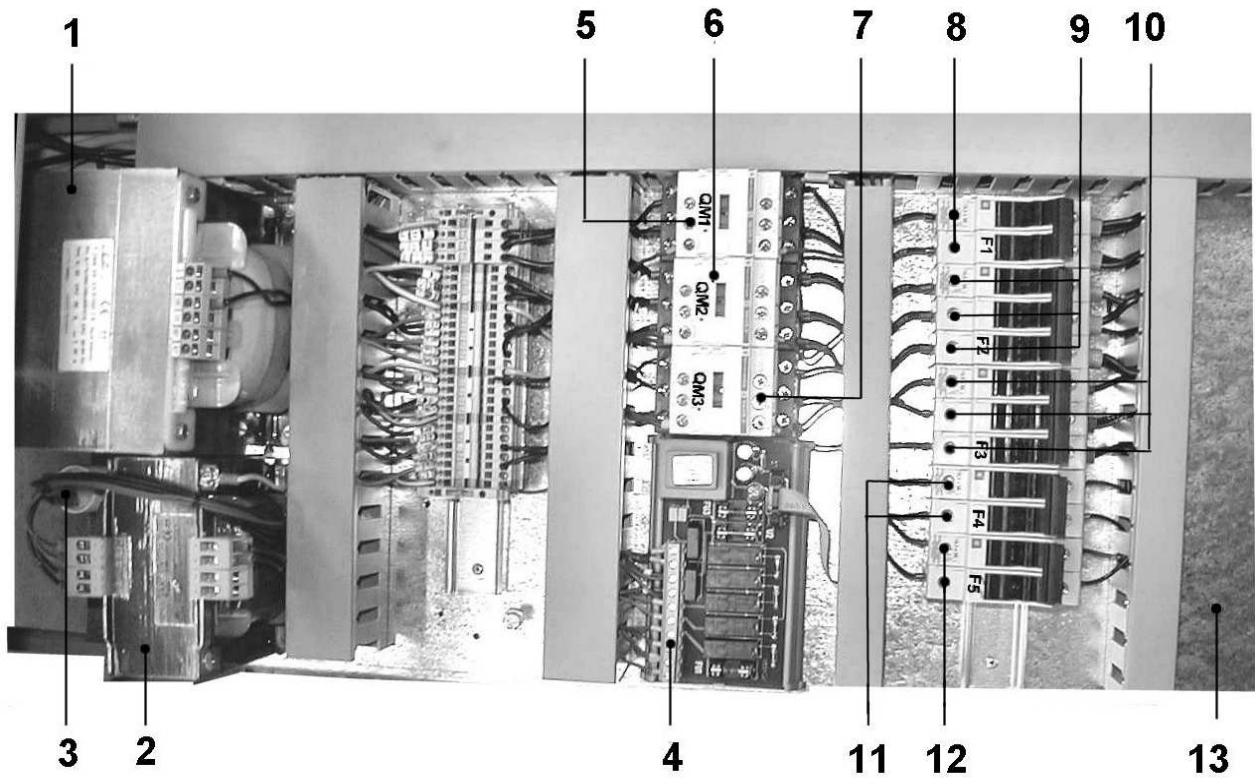

POS. POS.	CODICI PARTICOLARI ITEMS CODE	DENOMINAZIONI PARTICOLARI ITEMS DESCRIPTION	Q.tà Q.ty
1	FE440504 FE440505	Trasformatore 2500VA (380-415V) / Transformer 2500VA (380-415V) Trasformatore 2500VA (200-208-220V) / Transformer 2500VA (200-208-220V)	1
2	FE440026 FE440025	Trasformatore 400VA (380-415V) / Transformer 400VA (380-415V) Trasformatore 400VA (200-208-220V) / Transformer 400VA (200-208-220V)	1
3	FE088010 FE088001	Condensatore 5mf (380-415V) / Condenser 5mf (380-415V) Condensatore mf8 (200-208-220V) / Condenser mf8 (200-208-220V)	1
4	FE120334	Modulo potenza / Power board	1
5	FE110615 FE110615	Contattore LC1-D18B7 (380/415V) / LC1-D18B7 Contactor (380/415V) Contattore LC1-D18B7 (200/208/220V) / LC1-D18B7 Contactor (200/208/220V)	1 1
6	FE110602 FE110615	Contattore LC1-D09B7 (380/415V) / LC1-D09B7 Contactor (380/415V) Contattore LC1-D18B7 (200/208/220V) / LC1-D18B7 Contactor (200/208/220V)	1 1
7	FE110602 FE110602	Contattore LC1-D09B7 (380/415V) / LC1-D09B7 Contactor (380/415V) Contattore LC1-D09B7 (200/208/220V) / LC1-D09B7 Contactor (200/208/220V)	1 1
8	FE290405 FE290407	Fusibile 10A (380/415V) / Fuse 10A (380/415V) Fusibile 16A (200/208/220V) / Fuse 16A (200/208/220V)	2
9	FE290405 FE290407	Fusibile 10A (380/415V) / Fuse 10A (380/415V) Fusibile 16A (200/208/220V) / Fuse 16A (200/208/220V)	3
10	FE290402 FE290403	Fusibile 4A (380/415V) / Fuse 4A (380/415V) Fusibile 6A (200/208/220V) / Fuse 6A (200/208/220V)	3
11	FE290400 FE290401	Fusibile 1A (380/415V) / Fuse 1A (380/415V) Fusibile 2A (200/208/220V) / Fuse 2A (200/208/220V)	2
12	FE290401	Fusibile 2A / Fuse 2A	2
13	FM090103	Piastra / Plate	1

Schema elettrico Wiring diagram

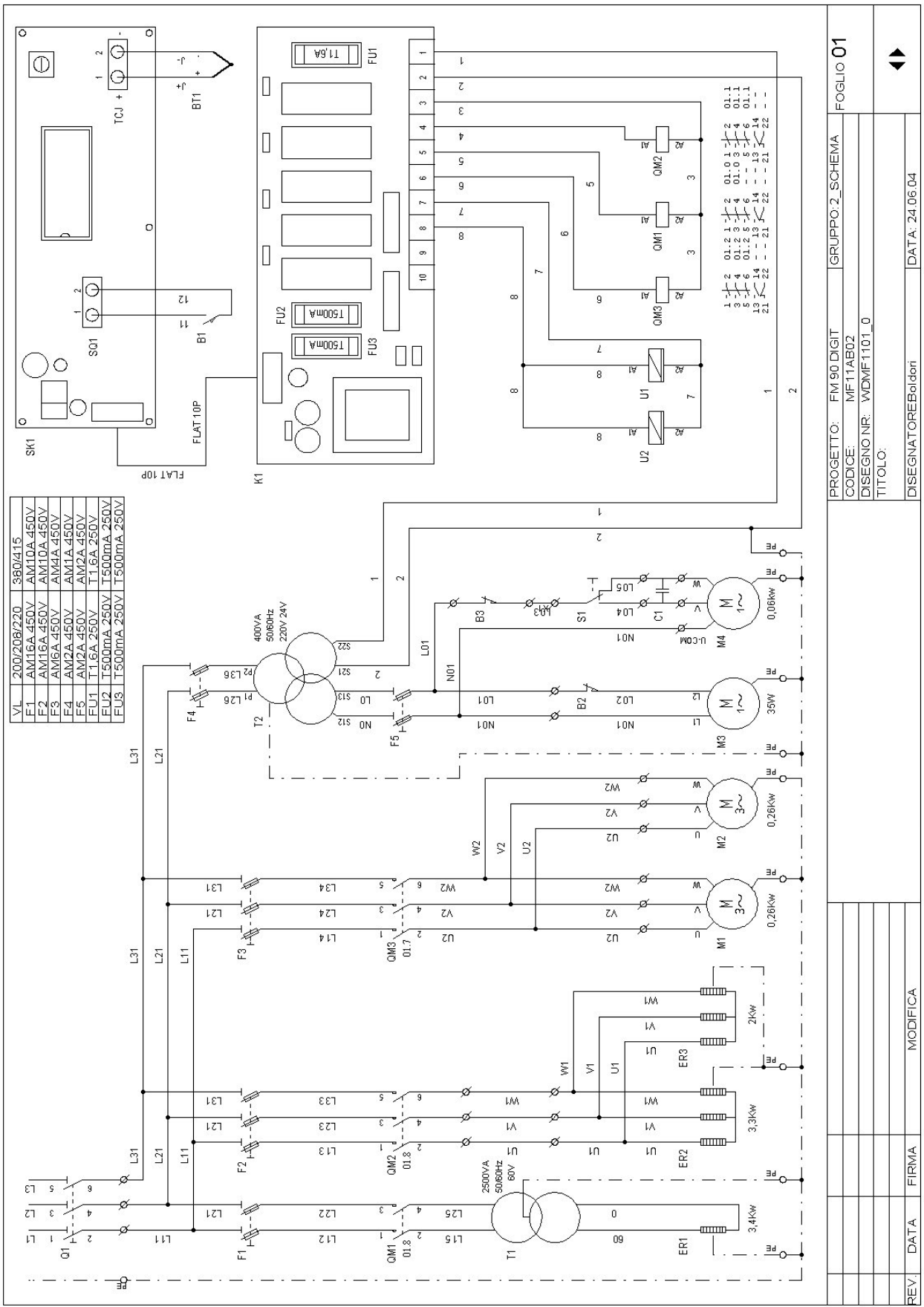

PROGETTO: FM 90 DIGIT CODICE: MF1TAB02 DISEGNO NR: WDMF1101_0 TITOLO:	GRUPPO:2_SCHEMA FOLGIO 01 DATA: 24.06.04
REV. DATA FIRMA MODIFICA	◀ ▶

Legenda schema elettrico

Wiring diagram description

Q1	Interruttore generale	Main switch
F1	Fusibili lama saldante 10.3X38	Sealing blade fuses 10.3X38
F2	Fusibili resistori 10.3X38	Heaters fuses 10.3X38
F3	Fusibili motori ventole 10.3X38	Fans motors fuses 10.3X38
F4	Fusibili trasformatore ausiliario 10.3X38	Auxiliary transformer fuses 10.3X38
F5	Fusibili motori avvolgitore/svolgitore 10.3X38	Winder/unwinder motors fuses 10.3X38
FU1	Fusibile scheda 5X20	Board fuse 5X20
FU2	Fusibile magnete di retrazione 5X20	Shrinking magnet fuse 5X20
FU3	Fusibile magnete di saldatura 5X20	Sealing magnet fuse 5X20
ER1	Resistenza lama saldante	Sealing blade heater
ER2/3	Resistori	Heaters
T1	Trasformatore di taglio	Cutting transformer
T2	Trasformatore ausiliario	Auxiliary transformer
M1/2	Motori ventole	Fans motors
M3	Motore avvolgitore	Winding motor
M4	Motore svolgitore	Unwinder motor
BT1	Termocoppia	Thermocouple
B1	Finecorsa ciclo macchina	Machine cycle limit switch
B2	Finecorsa avvolgitore	Winder motor
B3	Finecorsa svolgitore	Unwinder motor
QM1	Contattore lama saldante	Sealing blade contactor
QM2	Contattore resistori	Heaters contactor
QM3	Contattore motori ventole	Fans motors contactor
U1/2	Magneti di saldatura	Sealing magnet
C1	Condensatore	Condenser
S1	Deviatore motore	Motor deviator
K1	Modulo di rinvio potenza	Electronic control board
SK1	Scheda di comando	Control board



Minipack-torre S.p.A.

Via Provinciale, 54 - 24044 DALMINE (BG) - ITALY

Tel. (035) 563525 – Fax (035) 564945

E-mail: info@minipack-torre.it

Internet: www.minipack-torre.it